



MARS 23

VARCAS

### 01 | Multi-point locking

Multiple locking with a sleek lock body.

### 02 | Interlock Male-Female locking

The two pieces of the interlock lock together in their V-shaped grooves, eliminating the racking sound caused by wind and making the interlock air, water, and dust-proof.

### 03 | Roller Bearing

High-quality roller bearing for a smooth sliding experience.

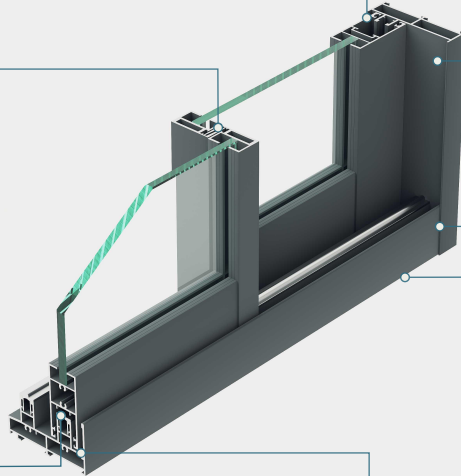

### 04 | Plain Side Track

The open space which is exposed to the interior side is designed plain for an extra aesthetic look.

### 05 | 90° Joivery

All the fitments of sections are done at 90°

### 06 | Conceal provision

A shutter guide is provided in the bottom frame which helps to conceal the whole system. For a seamless view.

### 07 | Wool pile with fin seal

A high-quality brush is used for all weather effects and for a better operating experience.

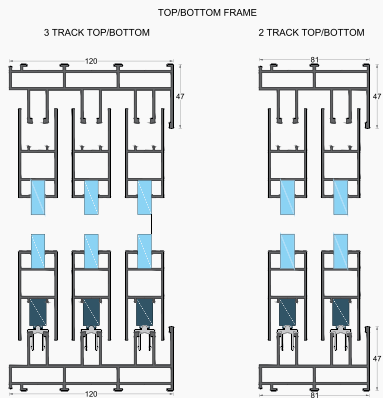
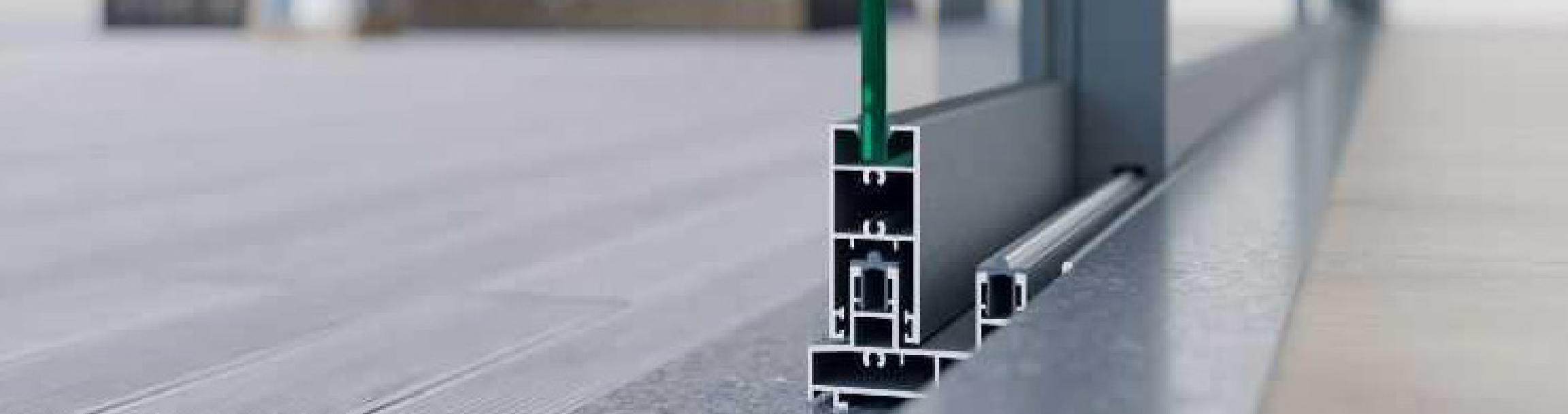

INTERLOCK



L & R TOP

3 TRACK SIDE FRAME

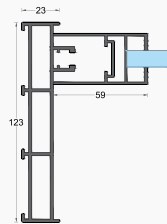

2 TRACK SIDE FRAME

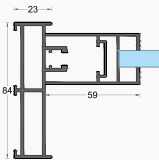

## Attributes

## Details

Sight Line Face Width	23mm
Face width	60mm
Frame height	47mm
Frame width	33mm
Profile thickness	1.5mm to 3mm
Max height of shutter	8'
Max size of shutter	32qft
Glazing	5mm to 18mm

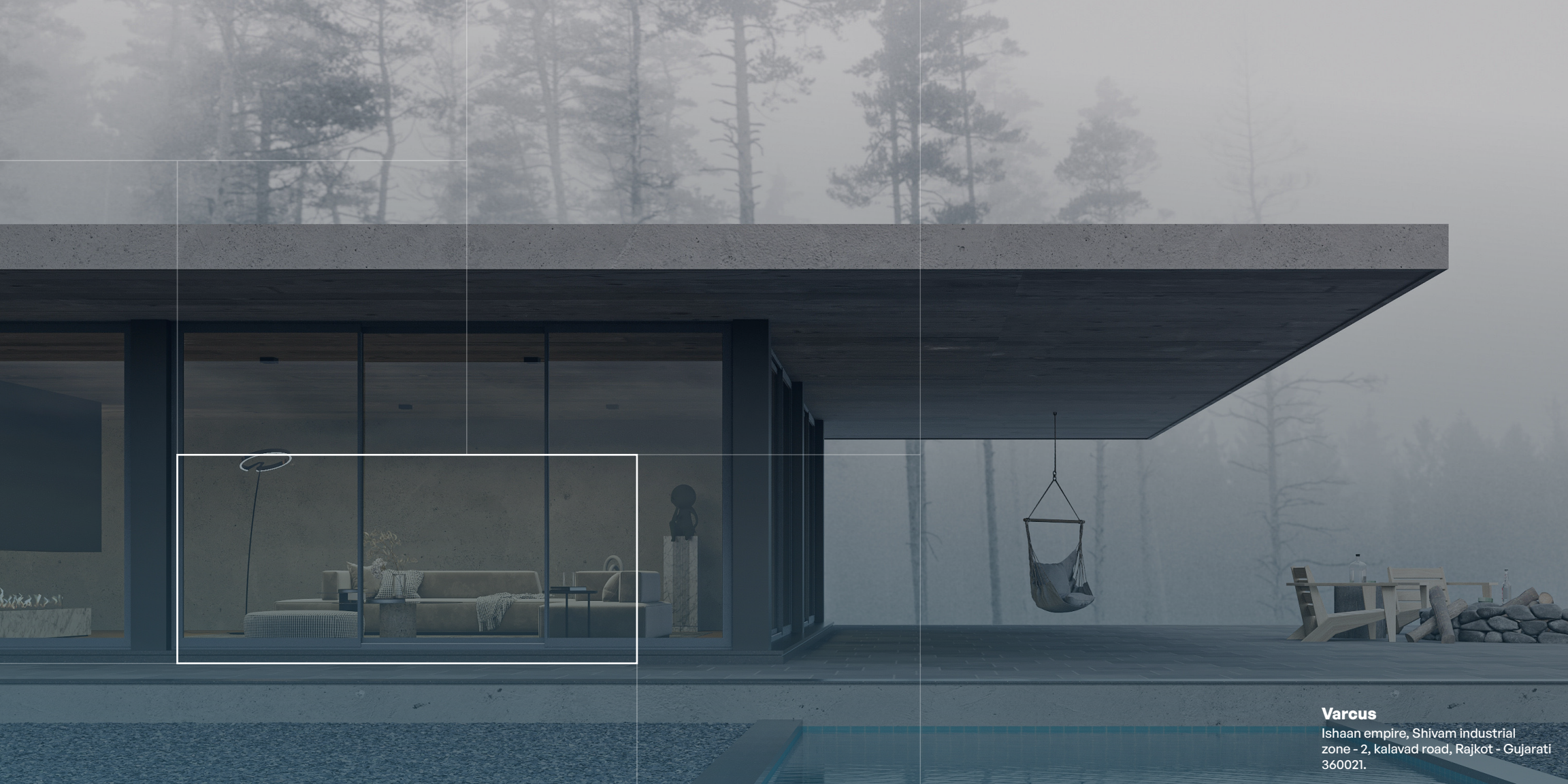

**Varcus**

Ishaan empire, Shivam industrial zone - 2, kalavad road, Rajkot - Gujarati 360021.